

ST Series USB Power Sensor

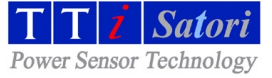

User's Guide



Measurably better value

Thurlby Thandar Instruments Ltd.
Glebe Road, Huntingdon, Cambridgeshire
PE29 7DR England (United Kingdom)
Tel: +44 (0)1480 412451
Fax: +44 (0)1480 450409
Email: info@tti-test.com
Web: www.tti-test.com

1 Welcome

Thank you for choosing the ST Series USB Power Sensors and welcome to the Satori Technology User's Guide.

This manual will guide you through the following sections:

- Software installation
- Hardware installation
- Using the software
- Getting more from your system

Introduction

The ST CW power sensors are a new series of products which connect directly to a laptop or desktop computer using a standard USB port, without the need for a stand alone meter. Measurements from the sensor can be displayed on the laptop or desktop computer or can be integrated into your test system with a set of user-defined software functions – supplied as standard.

This guide will take you through the software installation stages. Then it will outline some typical hardware configurations and how to get the most from your software. Finally, you will be shown how to integrate the sensor into your test environment.

Key Features

The key features of the ST CW power sensor are:

- Perfect for most Power measurement uses, including:
 - Installation and maintenance
 - Manufacturing test
 - ATE
 - Research & Development
- Easy to use software
- Quick configuration
- Flexible set-up and system integration
- Small, compact and rugged
- Multiple sensor support on single PC
- No reference calibration required
- Low cost alternative to tradition power measurements

What you should have

Before you start, please check you have the following items (Refer to Figure 1 "What you should have" on page 4):

- ST CW power sensor (ST124SMA or ST185SMA or ST265SMA or ST40K)
- 6 feet (1.82m) USB cable (S2004-61001)
- Satori Technology software CD (S2004-80001)
- Product warranty card (S2004-90014)
- This User's Guide (S2004-90001)

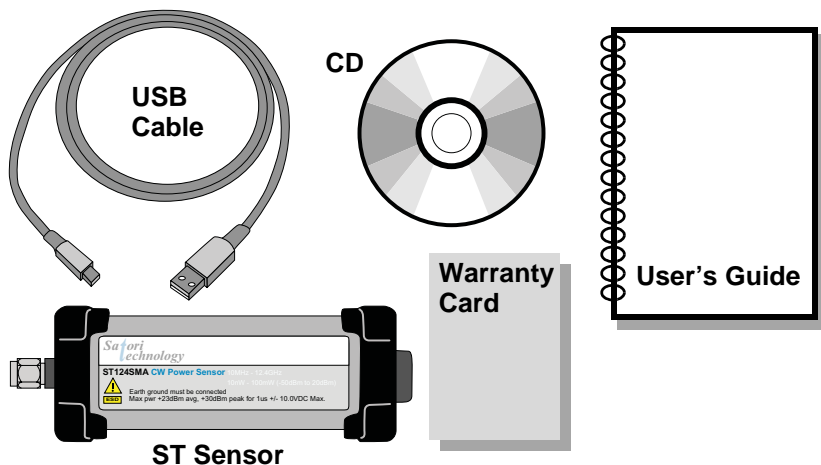

Figure 1 What you should have

If any of these items are missing or damaged, then please contact your local representative as soon as possible or refer to "Contacting Satori Technology" on page 59.

Contents

Welcome

Introduction	3
Key Features	3
What you should have	4

Installation Of Software

Install procedure	9
--------------------------	----------

USB Installation

Driver installation with Windows® XP SP2	13
Driver installation with Windows® XP SP1	16

Hardware Connections

How to connect your sensor	21
Connection to your PC	21
Connection to your unit under test (UUT)	22
Connecting multiple sensors	23

Using The Software

Using the software	25
Zero your sensor	26
Making a measurement	26
Measurements using more than one sensor	28
How to make a pulse power measurement	30
Measuring GSM mobile signals	31

Making a measurement	32
Measuring power greater than +20dBm (100mW)	33
Measuring an attenuator using relative mode	34
How to use measurement limits	35
How to use trace mode	38
Error and status messages	42
Sensor not zeroed	42
Sensor frequency, offset and duty cycle enabled	42
Sensor overload.	43
High limit exceeded	43
Low limit exceeded.	44
Zero sensor - temperature change.	44
Manually entered cal factor	45
Description of software	46
Description of icons	46
Description of menu options.	47

Enhanced Features

Integrating your power sensor	49
--------------------------------------	-----------

Troubleshooting

How to fix “No Sensor Connected” problems	51
No sensor is attached to your PC	52
The wrong USB driver has been installed	52
The USB cable or USB port are faulty	53
Incorrectly configured USB hub	53
More than one application has been started	54
Unexpected measurements results	54
Check status messages.	54

Your sensor is potentially damaged 54
Incorrect offset setting 54
Incorrect measurement settings 54

How to identify your PC operating system 55

Other useful information 56

What is zeroing? 56
Pulse measurement and setting the duty cycle. 56
What is a dB? 57
What is a dBm? 58

Contact & Support

Contacting Satori Technology 59
Our Website 59

Safety & Specifications

Safety notices 61
EC declaration of conformity 62
WEEE Directive. 63

Product descriptions and requirements 63
Minimum PC requirements 63
ST124SMA Description. 63
ST185SMA Description. 63
ST265SMA Description. 63

Index 65



1 Installation Of Software

This chapter provides information about installing the Satori Technology power sensor software.

Caution

Do not connect any hardware to your PC until you have installed the Satori Technology software.

Before you start, please check your PC for software compatibility. Refer to “Minimum PC requirements” on page 63 for more information.

Install procedure

To install the Satori Technology software, follow these steps:

Note

If you are using Windows XP SP1, disconnect any LAN connections. This will prevent your PC automatically downloading the wrong USB drivers.

Do this	Comment
1 Insert the CD into your PC	The installation should start automatically.
2 (Optional) If the installation does not start automatically, select Start > Run and type d:\SatoriSensorInstallation.exe	Where D:\ is the name of your CD drive.
3 Select Continue	Refer to Figure 2 on page 10.

Do this

Comment

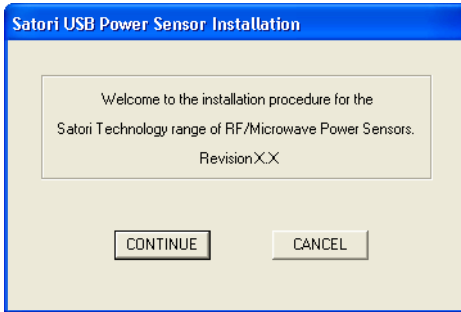

Figure 2 Start of installation software

- 4 Check the software matches your sensor types and then select **Continue**

The sensor part numbers are listed on the side of the sensor. Refer to Figure 3 on page 10.



Figure 3 Check sensor part number

- 5 Carefully read all of the License Agreement. If you accept the terms and conditions of the license agreement, enable the **Accept** option and then select **Continue**

If you have any questions about this agreement, then please contact us. Refer to Figure 4 on page 11.

Do this

Comment

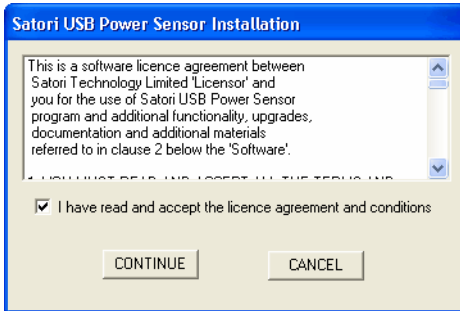

Figure 4 License agreement

- 6 Choose the installation location, whether you want a desktop icon and a shortcut added to your start menu, then select **Continue**

It is recommended that you use the default installation options. Refer to Figure 5 on page 11.

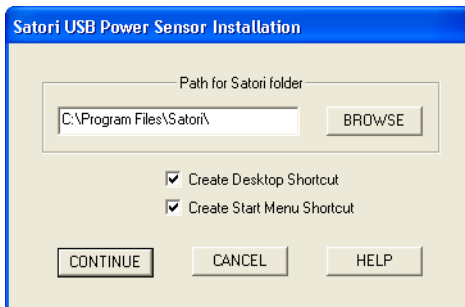

Figure 5 Installation location

- 7 Select **Finish** when the installation has completed

Refer to Figure 6 on page 12.

Do this

Comment

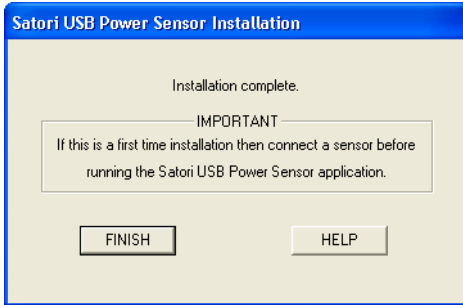

Figure 6 Installation completed

Note

At the end of the installation you are asked to connect your sensor. Refer to "USB Installation" on page 13 for more information.

2 USB Installation

This chapter explains the process for installing and enabling the USB drivers for your ST CW power sensor. These drivers are required to enable effective measurement data transfer.

Caution

Do not connect your sensor and install the USB drivers unless you have installed the Satori Technology software. Refer to “Installation Of Software” on page 9 for more information.

There are two USB driver installation procedures covered in this chapter – one for Windows® XP SP1 and the other for Windows® XP SP2. To identify which operating system you have on your PC, refer to “How to identify your PC operating system” on page 55.

Driver installation with Windows® XP SP2

This section describes how to install and configure your USB drivers on a PC with Windows® XP and service pack 2 (SP2) operating system.

	Do this	Comment
1	Connect your sensor to the USB port of your PC. The Windows Hardware Wizard starts automatically.	Refer to “How to connect your sensor” on page 21 for more information.
2	Choose “ No not at this time ” and select Next .	Refer to Figure 7 on page 14.

Do this

Comment



Figure 7 Windows hardware installation wizard

3 Choose “**Install from a list or specific location (Advanced)**” and select **Next**.

Refer to Figure 8 on page 14.

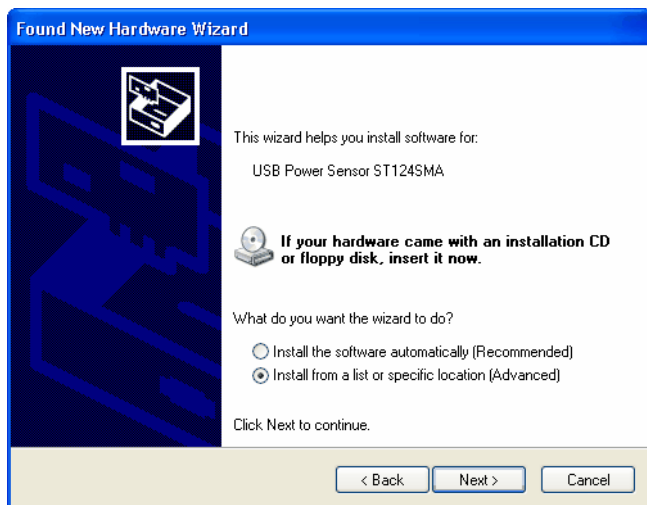

Figure 8 USB Driver location

Do this	Comment
4 Choose "Include this location in the search" .	Refer to Figure 9 on page 15.

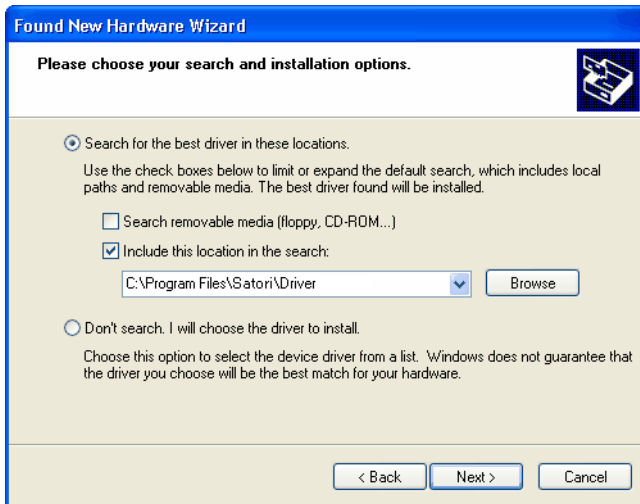

Figure 9 Choose the installation location

5 Browse to the following location: C:\Program Files\Satori\Driver .	If you have changed the default installation location, navigate to the Satori installation folder.
6 Select Next .	
7 (Optional) During the installation Windows may check the driver compatibility. Select Continue Anyway .	The USB sensor driver is a valid driver and will not damage your system. Refer to Figure 10 on page 16.

Do this	Comment
---------	---------



Figure 10 Continue Anyway with installation

- | | |
|--|---|
| 8 The driver will now be installed. | |
| 9 Select Finish when the driver installation is complete. | Windows will now confirm it has identified the USB sensor hardware. |

The USB driver that is installed is a generic USB sensor driver and it is used for a range of USB sensors. The sensor driver installed on your PC is called **FTDI FT8U2XX Device**.

Driver installation with Windows® XP SP1

This section describes how to install and configure your USB drivers on a PC with Windows® XP and service pack 1 (SP1) operating system.

Caution Disconnect any LAN connections to the PC.

Windows® XP SP1 does not provide flexible USB driver installation. The operating system first attempts to obtain the USB driver from an external source. This external driver does not provide a working connection with your sensor.

	Do this	Comment
1	Connect your sensor to the USB port of your PC. The Windows Hardware Wizard starts automatically.	Refer to “How to connect your sensor” on page 21 for more information.
2	Choose “ No not at this time ” and select Next .	Refer to Figure 7 on page 14.

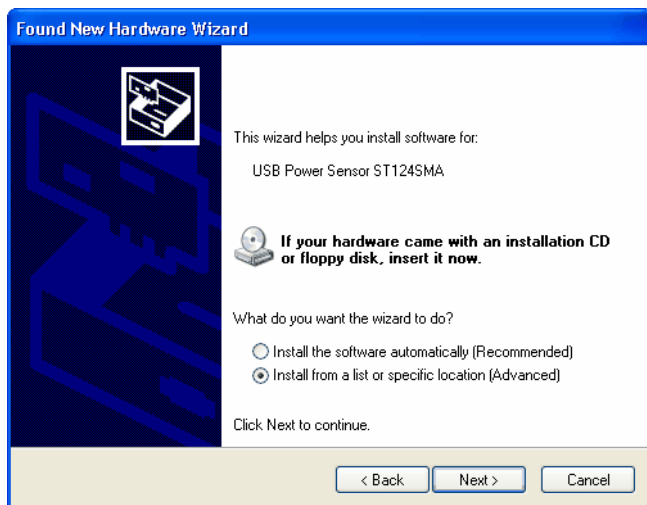

Figure 11 Windows hardware installation wizard

3	Choose “ Install from a list or specific location (Advanced) ” and select Next .	Refer to Figure 8 on page 14.
---	--	-------------------------------

Do this

Comment

**Figure 12** USB Driver location**4** Choose “Include this location in the search”.

Refer to Figure 9 on page 15.

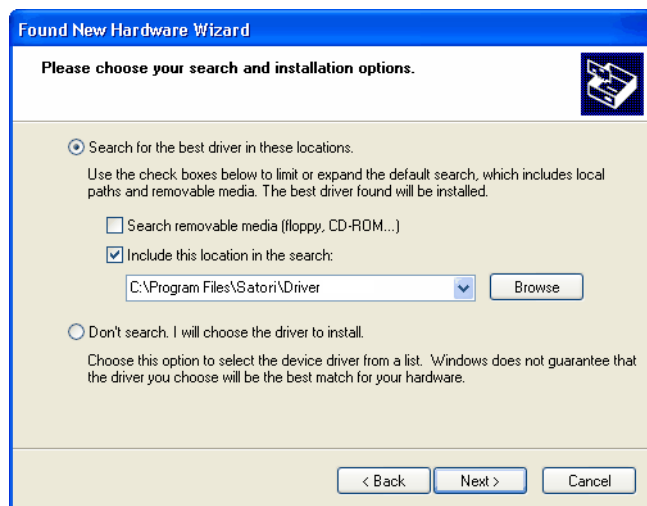
**Figure 13** Choose the installation location

Do this	Comment
5 Browse to the following location: C:\Program Files\Satori\Driver.	If you have changed the default installation location, navigate to the Satori installation folder.
6 Select Next.	
7 (Optional) During the installation Windows may check the driver compatibility. Select Continue Anyway.	The USB sensor driver is a valid driver and will not damage your system. Refer to Figure 10 on page 16.



Figure 14 Continue Anyway with installation

8 The driver will now be installed.	
9 Select Finish when the driver installation is complete	Windows will now confirm it has identified the USB sensor hardware.

Reconnect your LAN connection.

The USB driver that is installed is a generic USB sensor driver and it is used for a range of USB sensors. The sensor driver installed on your PC is called **FTDI FT8U2XX Device.**

If this is not the driver installed on your PC, refer to “How to fix “No Sensor Connected” problems” on page 51 for more information.

3 Hardware Connections

This chapter provides an overview of how to connect your ST CW power sensor in your test environment.

How to connect your sensor

The section describes some typical connection configurations.

Connection to your PC

Connection to your PC is through a USB cable (supplied with your sensor). The ST CW power sensor is USB 2.0 compatible.

It is recommended that you use the USB cable supplied with your sensor.

Refer to Figure 15 "Sensor to PC connection" on page 21 for a diagram of the sensor and PC connection.

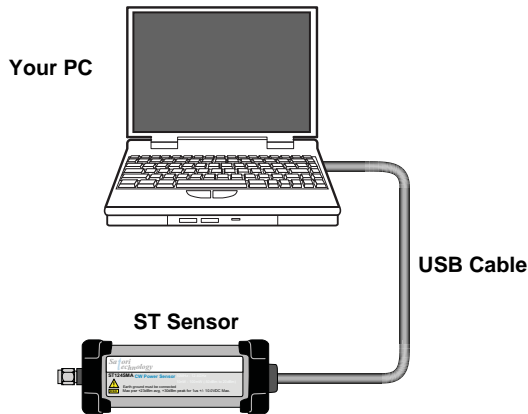

Figure 15 Sensor to PC connection

The maximum recommended connection length is 5m.

Connection to your unit under test (UUT)

The ST CW power sensor has a standard SMA-m connection port.

The recommended torque for the SMA-m connection is 5 lbs/in (0.5 Nm).

Caution Do not turn the body of the sensor when connecting the sensor to a unit under test (UUT). To avoid internal sensor damage, connect and disconnect the sensor by turning the metal nut only.

Refer to Figure 16 "Typical sensor to UUT connection" on page 22 for a diagram of the sensor connection.

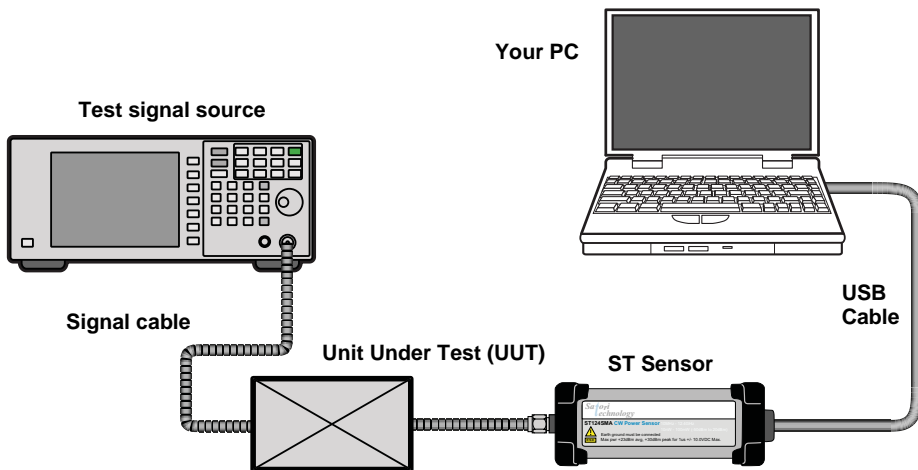

Figure 16 Typical sensor to UUT connection

Caution Ensure that you do not apply any excessive force on the sensor once it has been connected.

Connecting multiple sensors

It is possible to connect and monitor multiple sensors. The number of sensors you can connect to your PC depends on your system configuration. For example, you may chose to use a USB hub interface. If this is the case, then carefully read the USB hub manufacturer's instructions when connecting and configuring external USB devices.

Refer to Figure 17 "A typical multiple sensor configuration" on page 23 for a diagram of a typical multiple sensor configuration.

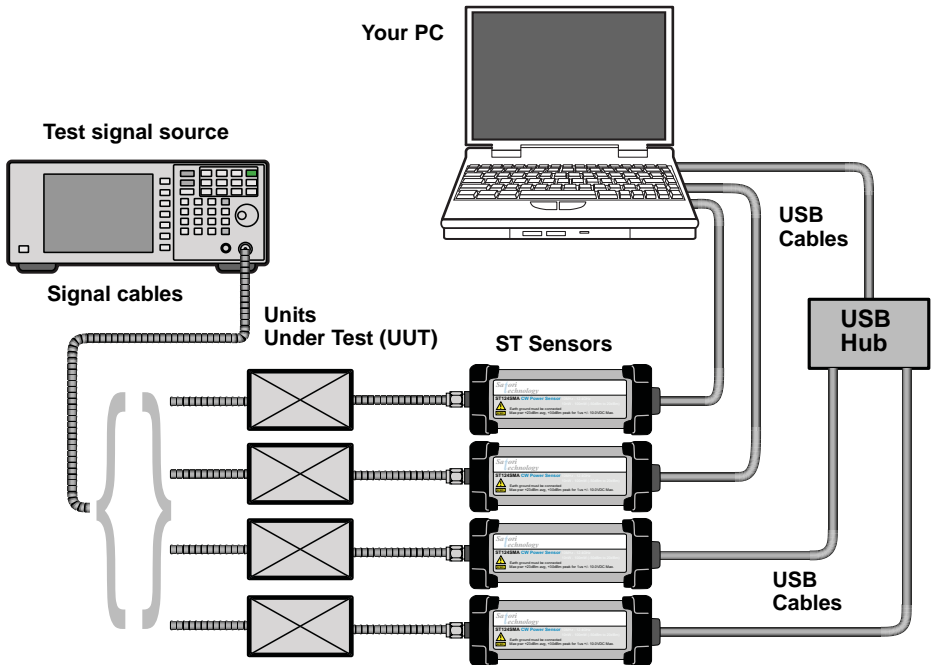



Figure 17 A typical multiple sensor configuration

4 Using The Software

This chapter describes how to use the Satori Technology software when making typical power measurements. It also provides a description of the user interface and key features of the software.

Using the software

Once you have installed the software, configured your USB drivers and connected your hardware, you are ready to make measurements using the Satori Technology software.

If you chose the default installation, you should have an icon  on your desktop for the test software. Double-click on this icon to start the application. Refer to Figure 18 on page 25 for an example start-up interface.

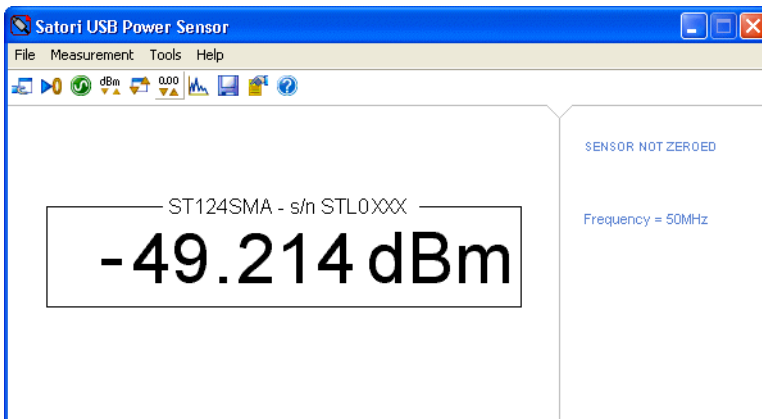



Figure 18 Default start-up interface

When the software is started, measurement results are displayed straight away. However you are reminded that you should zero the sensor.

Zero your sensor

On the right side of the user interface you are reminded that the sensor is not zeroed. For more information on zeroing your sensor, refer to “What is zeroing?” on page 56. Use the following procedure to zero your measurement sensor:

Do this	Comment
1 With the sensor still connected, select the zero icon  .	Or select Measurement > Zero Sensor
2 Confirm you wish to zero the sensor, select OK .	Ensure no power is being applied to the sensor during this process.
3 Wait until the zeroing is completed.	When the zero process is complete, the reminder is removed from the user interface.

Making a measurement

The following procedure outlines a typical measurement procedure.

Do this	Comment
1 Zero the sensor.	Refer to “Zero your sensor” on page 26.
2 Open the measurement control panel. Select the control panel icon  or select Measurement > Control Panel .	Refer to Figure 19 on page 27.

Do this

Comment

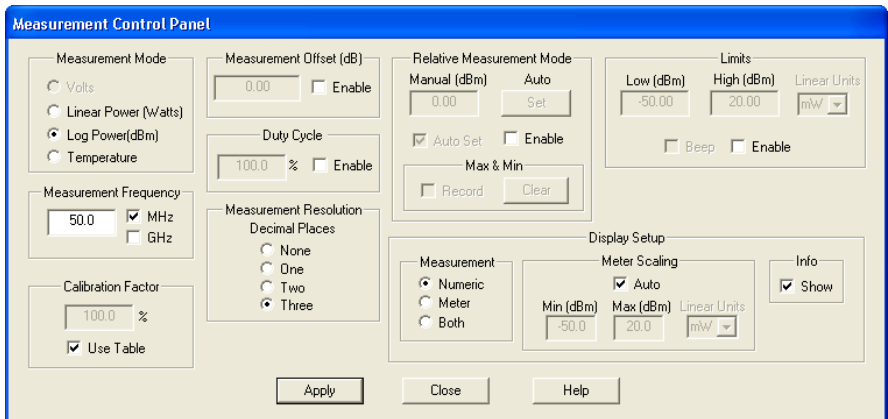

Figure 19 Control panel

3 Choose **Log Power** from the measurement mode section of the control panel dialog box.

Top left corner of the dialog box.

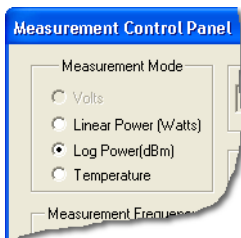

Figure 20 Log power

4 Enter the desired measurement frequency.

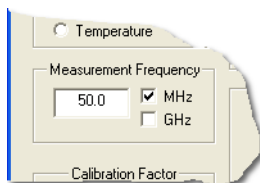

Figure 21 Set frequency

Do this	Comment
5 Choose Use Table in the calibration factor section of the control dialog box. This uses the sensor's internal calibration table.	Refer to Figure 22 on page 28.

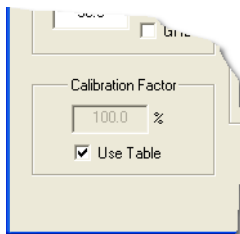

Figure 22 Use table

6 Select Apply and Close the measurement control panel.
--

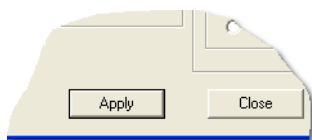

Figure 23 Apply button

7 Enable the unit under test (UUT) providing a signal to the sensor.
8 The power measurement is displayed.

For definitions of **dB** and **dBm**, refer to “What is a dB?” on page 57 and “What is a dBm?” on page 58.

Measurements using more than one sensor

It is possible to make multiple measurements using multiple USB sensors and multiple instances of the sensor software. Start the Satori Technology software for each sensor connected to your PC. Follow this procedure:

Do this	Comment
1 Connect all your sensors to your PC.	
2 Double-click on the desktop icon for the Satori Technology software.	
3 To identify which sensor you are connected to, match the serial number on the display with the serial number on the sensor.	Refer to Figure 24 on page 29.

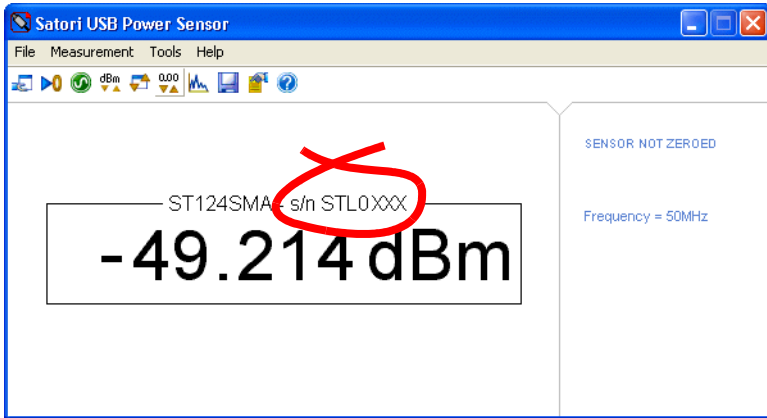

Figure 24 Sensor serial number identification

4 Configure your measurement software.	Refer to “Making a measurement” on page 26.
5 Again, double-click on the desktop icon for the Satori Technology software and start another application.	
6 Identify the sensor and configure your measurement.	
7 Repeat this process (steps 2-4) for each sensor attached to your PC.	

How to make a pulse power measurement

The following procedure outlines how to set up and make a pulse power measurement. For more information on pulse power measurement refer to “Pulse measurement and setting the duty cycle” on page 56.

Do this	Comment
1 Open the application.	
2 Zero your sensor.	Refer to “Zero your sensor” on page 26.
3 Open the measurement control panel. Select the control panel icon or select Measurement > Control Panel .	
4 Enable the duty cycle option and set the duty cycle percentage.	Refer to Figure 25 on page 30.

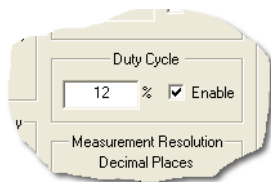

Figure 25 Setting the duty cycle

- 5 Set the Calibration Factor.
- 6 Select **Apply**.

The pulse repetition rate should be above 200 Hz for the internal averaging to be effective. Below this pulse RF measurement (PRF), the reading will vary. The duty cycle feature may be used down to around 1%. The peak power limit of the sensor should however strictly be adhered to. Refer to Figure 26 on page 31 for more information.

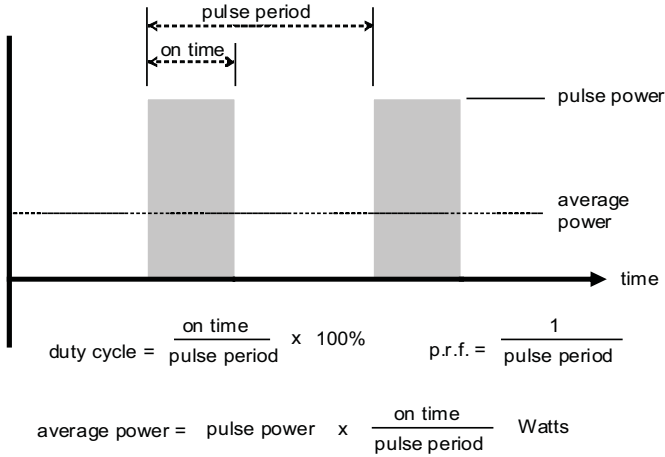

Figure 26 Typical RF burst

Measuring GSM mobile signals

Note This measurement example is based on the ST124SMA sensor.

GSM mobile signals are usually present for a single time-slot per frame, that is, for approximately one eighth of the time, since there are eight time slots per frame.

The mobile transmitter is active for slightly less than this time because the transmitter has around three 'tail' bits to ramp up and down in power, and 8.25 guard bits where the transmitter is silent. This means that the transmitter is inactive for 11.25 bits out of 156.25.

That is for roughly $(156.25 - 11.25) / 156.25 = 0.928$ of a time slot.

The duty cycle of the transmitter is then $12.5\% * 0.928 = 11.6\%$. Refer to Figure 27 on page 32.

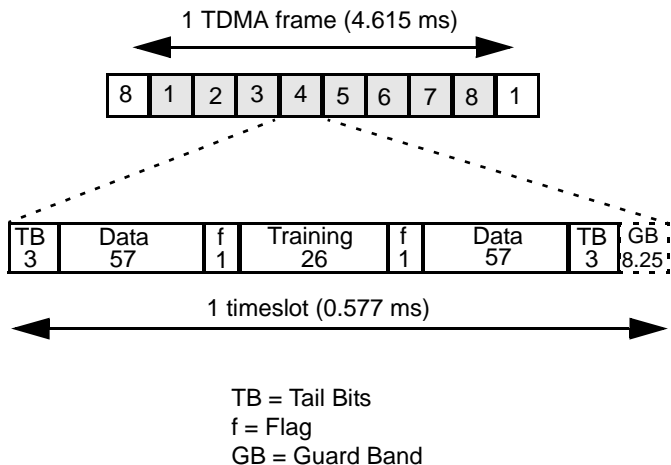

Figure 27 GSM TDMA structure and normal burst

In some cases, when the modulation is GPRS, multiple time slots are used. The correct duty cycle can be found by multiplying 11.6% by the number of active time-slots.

Making a measurement

Follow this procedure:

Do this	Comment
1 Start the application.	
2 zero the sensor.	Refer to “Zero your sensor” on page 26.
3 Open the measurement control panel. Select the control panel icon or select Measurement > Control Panel .	
4 Enable the duty cycle option and set the duty cycle percentage to 11.6%.	
5 Select Apply .	The sensor will read the GSM phone power in the active part of the time slot with reasonable accuracy.

Measuring power greater than +20dBm (100mW)

Caution

Do not apply more than +20dBm directly to the sensor. This level of power will damage the sensor.

The offset facility is useful when an attenuator or amplifier is used ahead of the sensor.

For example, if a 10.00 dB attenuator could be placed before the sensor to measure powers up to +30dBm (1 Watt).

Do this	Comment
1 Connect the sensor and open the application.	Refer to "Making a measurement" on page 32.
2 Zero the sensor.	Refer to "Zero your sensor" on page 26.
3 Set the measurement frequency.	This is set in the measurement control panel.
4 Insert the RF attenuator in front of the sensor. The power reading decreases by the attenuation value.	
5 In the measurement control panel, enable 'Measurement Offset (dB)' and enter the value of the attenuator.	A positive number for attenuation, negative for gain.
6 The power reading will now increase by the value entered. This counteracts the decrease in the displayed reading caused by the attenuator. The offset value also appears on the application software.	
7 The sensor and attenuator now measure from -40 dBm to +30 dBm.	Refer to Figure 28 on page 34.

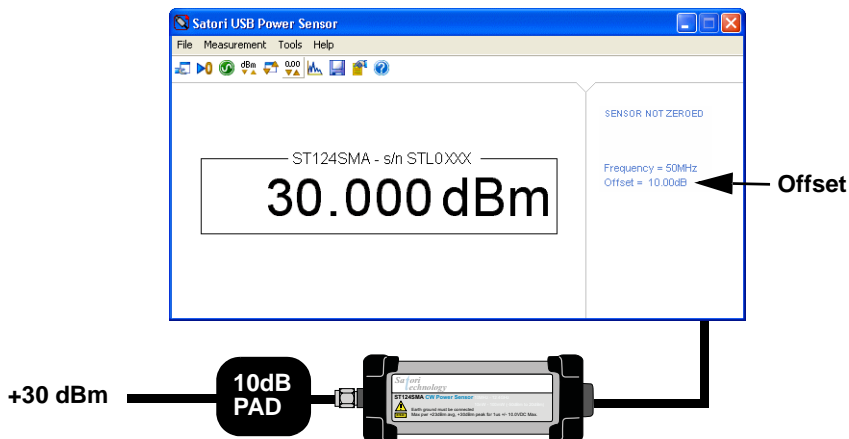

Figure 28 Sensor configuration using an attenuator

Measuring an attenuator using relative mode

Use relative mode to measure an attenuator, similar to the type used when measuring power greater than +20dBm. The process is as follows:

Do this	Comment
1 Connect the sensor and open the application.	Refer to “Making a measurement” on page 32.
2 Zero the sensor.	Refer to “Zero your sensor” on page 26.
3 Set the measurement frequency.	This is set in the measurement control panel.
4 Connect the sensor to a signal generator and attenuator.	Set the signal generator level so that it will not damage to sensor, even without the attenuator.
5 In the measurement panel, enable relative measurement mode.	Refer to Figure 29 on page 35.

Do this

Comment

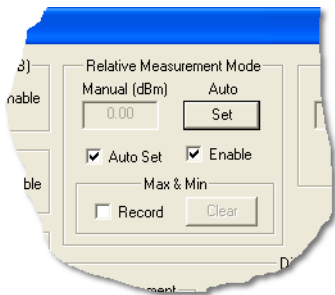

Figure 29 Enable relative measurement mode

- | | | |
|----------|--|---------------------------------|
| 6 | Select the Set button. | The display should be 0.000 dB. |
| 7 | Remove the attenuator and reconnect the sensor to signal generator. | |
| 8 | The sensor now reads the value of the attenuator, in dB, at the measurement frequency. | |
| 9 | This value may be entered in the measurement offset. | |

How to use measurement limits

The limit facility is useful for placing a guard band around a measurement.

For example, if the output from a device is +3dBm and must stay within 1dB of that level, then the limits facility can be used to warn you if the output rises above 4dBm or falls below 2dBm. Follow this procedure:

Do this

Comment

- | | | |
|----------|--|---|
| 1 | Connect the sensor and open the application. | Refer to “Making a measurement” on page 32. |
| 2 | Zero the sensor. | Refer to “Zero your sensor” on page 26. |

Do this	Comment
3 Set the measurement frequency.	This is set in the measurement control panel.
4 In the measurement control panel, enable the limits options.	Refer to Figure 30 on page 36.

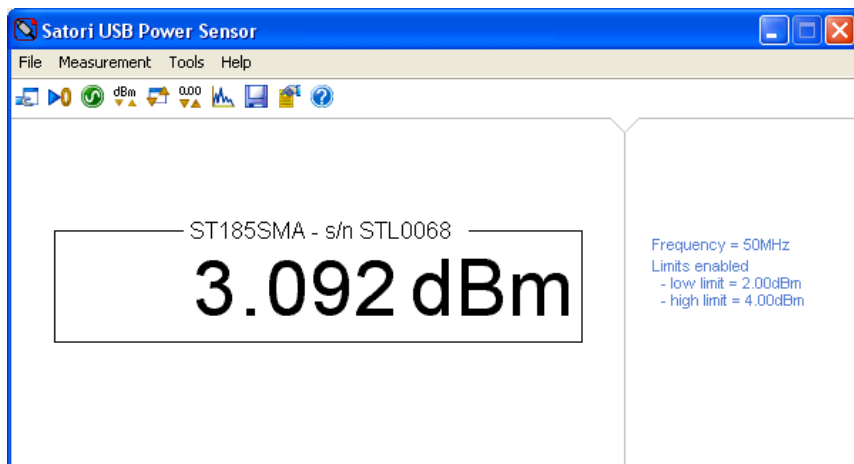

Figure 30 Setting measurement limits

5 Set the Low (dB) limit to 2dBm.	
6 Set the High (dB) limit to 4dBm	These limit settings are shown on the status area of the user interface.

If the level drops below 2dBm then a low limit warning message will appear. Refer to Figure 31 on page 37.

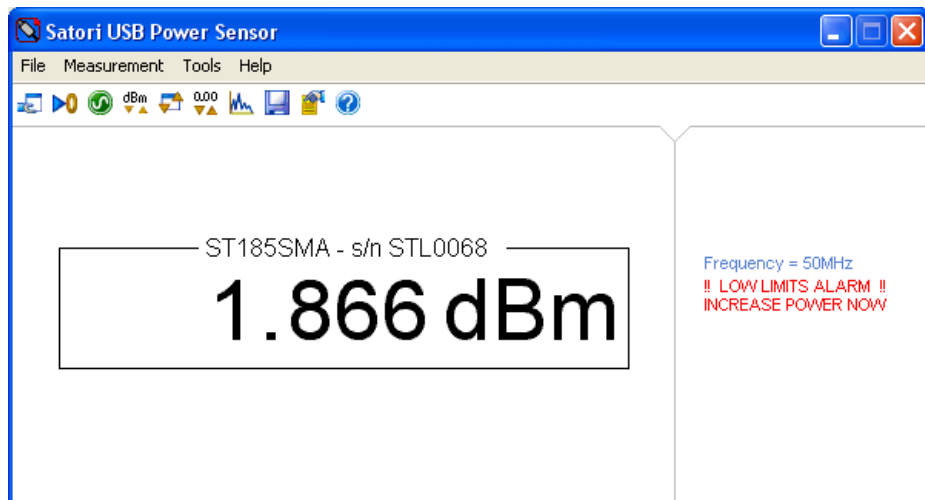

Figure 31 Low limits warning message

If the level rise above 4dBm then a high limit warning message will appear. Refer to Figure 32 on page 37.

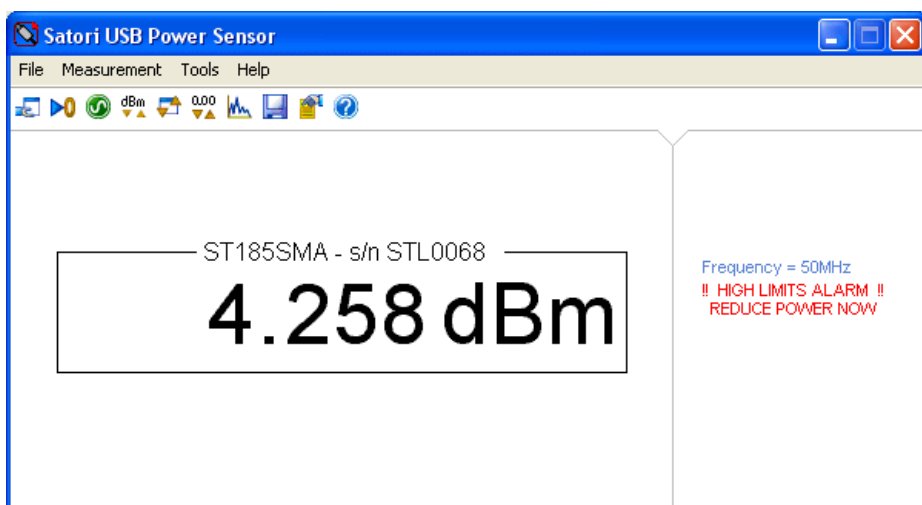



Figure 32 High limit warning message

How to use trace mode

The trace facility is useful for plotting the level being measured by the sensor over a period of time.

To configure a trace, open the trace control dialog box. Select the trace icon  or select **Tools > Trace...**

The trace is configured as follows:

Do this	Comment
1 Set the number of samples.	This is the number of samples to be taken for the trace.
2 Set the sample period.	This is the time between the plotted points. Refer to Figure 33 on page 38.

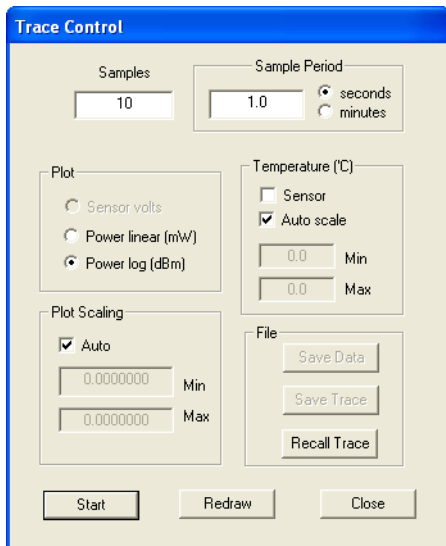

Figure 33 Trace control dialog box

- | | |
|----------------------|--|
| 3 Set the plot type. | Power linear (watts) or power log (dBm). |
|----------------------|--|

Do this	Comment
4 Set the plot scaling to Auto.	The Y-axis is automatically scaled to suit the Min and Max values associated with the level being plotted.
5 (Optional) Disable plot scaling.	The Y-axis uses the entered Min and Max values.
6 Set temperature display, enable the sensor option.	The temperature is displayed with a red trace.
7 (Optional) Enable the Auto Scale option.	<p>The Y-axis is automatically scaled to suit the Min and Max temperature values.</p> <p>If auto scaling is not selected, then Min and Max values for the temperature Y-axis can be entered into the Min and Max boxes.</p>
8 Select Start to begin the real-time trace.	Refer to Figure 34 on page 39.

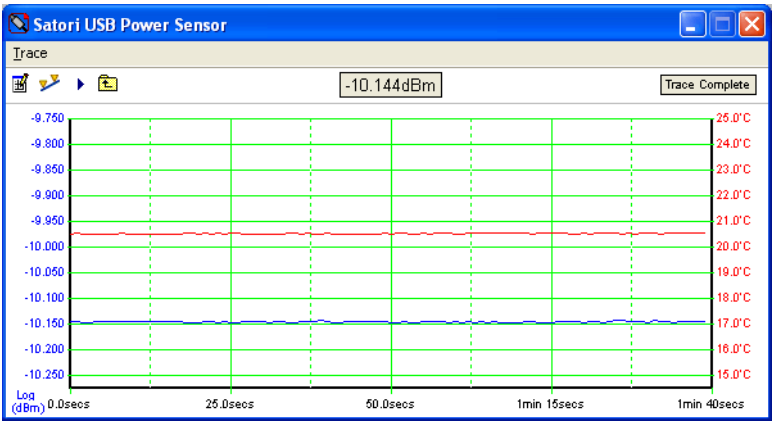

Figure 34 Typical trace with temperature

While the trace is drawing, the scaling can be altered by selecting the settings icon or selecting **Trace > Settings** on the menu bar. Also, the trace can be stopped by selecting the stop icon or selecting **Trace > Stop** on the menu bar. Refer to Figure 35 on page 40.

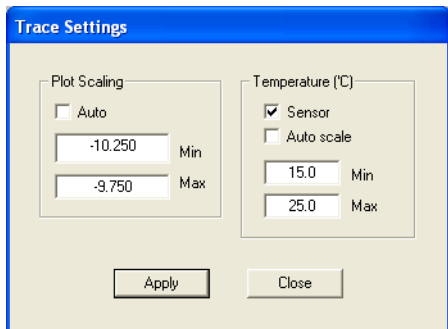

Figure 35 Trace settings dialog box

When the trace is complete, markers for making X & Y measurements can be turned on by selecting the markers icon or selecting **Trace > Markers** in the menu bar. Refer to Figure 36 on page 40.

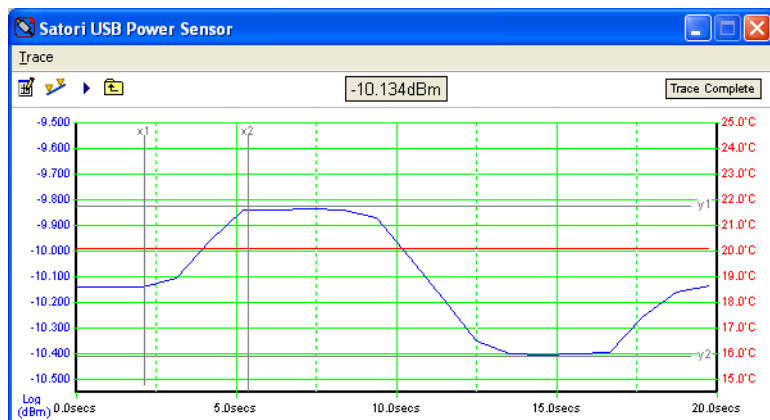



Figure 36 Trace markers

The displayed trace can be saved by selecting the **File > Save Trace** in the trace control dialog box. A trace can be recalled by selecting **File > Recall Trace**. The raw data used to draw the trace can be saved in a file by selecting the **Save Data** icon.

To exit trace mode select the exit icon or select **Trace > Exit**.

Note

Do not select the window close icon at the top right of the application to exit the trace feature as this closes the whole application. Instead select the close icon .

Error and status messages

The right side of the users interface displays a series of warnings and status messages. These are described as follows:

Sensor not zeroed

This message is displayed when the application first detects a sensor or the sensor needs to be re-zeroed. Refer to “Zero your sensor” on page 26 for more information. Refer to Figure 37 on page 42.

Sensor frequency, offset and duty cycle enabled

These message let you know your measurement frequency setting. It also shows if offset has been enable along with the duty cycle. Refer to Figure 37 on page 42.

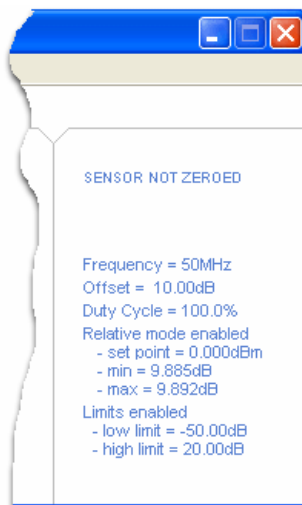

Figure 37 Frequency, Offset and Duty Cycle messages

Sensor overload

This warning message indicates a sensor overload. Refer to Figure 38 on page 43.

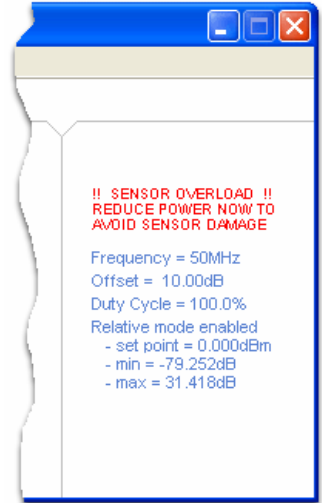

Figure 38 Sensor overload warning message

High limit exceeded

This warning message tells you when you have exceeded the high measurement limit you have set in the measurement control panel. When you see this warning message, reduce the power being tested. Refer to Figure 39 on page 43.

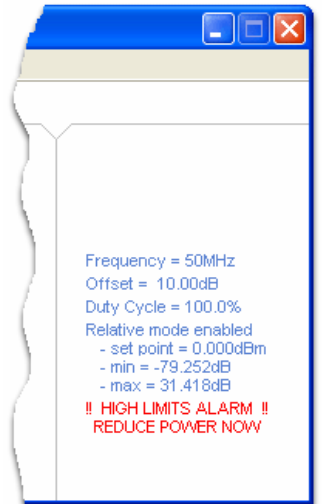

Figure 39 High limit warning

Low limit exceeded

This warning message tells you when you have exceeded the low measurement limit you have set in the measurement control panel. When you see this warning message, increase the power being tested. Refer to Figure 40 on page 44.

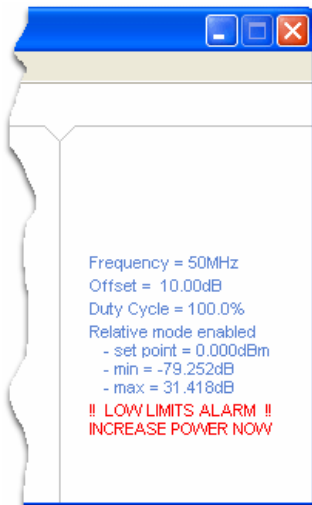

Figure 40 Low limit warning

Zero sensor - temperature change

When the temperature of the sensor is too great for the reliable measurement to be made, the zero sensor and temperature warning message is displayed. Refer to Figure 41 on page 44.

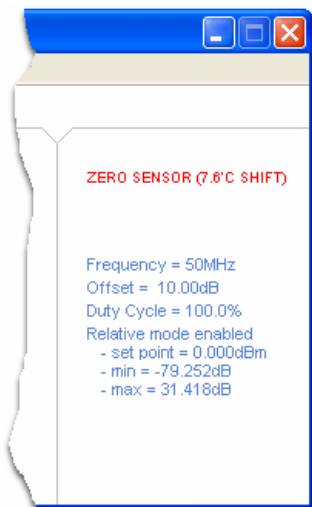
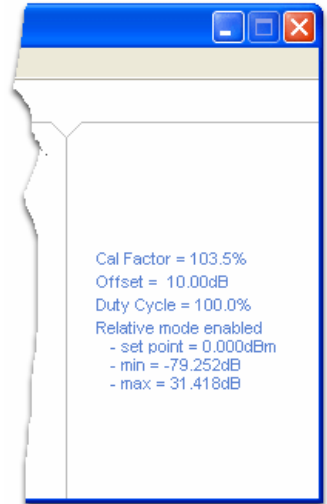

Figure 41 Zero shift warning

Manually entered cal factor

When you have entered a cal table, the entries are displayed on the user interface. Refer to on page 45.













Manually entered cal table

Description of software

The following section describes the basic software features. For more information on the software and menu options, refer to the online help in the application.

Description of icons

The icons, along the top of the application, are used for accessing the most common tasks. The icons are used as follows:

Icon	Description
	Opens the control panel.
	Starts the zero sensor process.
	Sets the sensor frequency.
	Changes the display between dBm nW.
	Changes the display between numerical or numerical with graphical data display to just a graphical display.
	Changes the number of decimal places being displayed.
	Opens the trace setting dialog box.
	Saves the current data.
	Recalls (Open) saved data.
	Opens the application help.

Description of menu options

The following describes the menu options from the application.

File Menu

Save Setup

Allows current setup to be saved to a simple text file.

Recall Setup

Allows a previous setup to be recalled.

Firmware download

Lets you update the firmware revision of the sensor.

Exit

Exits the application.

Measurement Menu

Control Panel

The control panel is used for setting most of the user interface components and key measurement factors. The control panel is divided into areas for configuring your measurement environment.

Zero Sensor

This performs a sensor zeroing process and will remove any offsets before making a measurement. This function should be carried out typically for values less than -35dBm. Refer to "What is zeroing?" on page 56 for more information.

Preset

Resets all your configured measurements back to the factory default settings.

Tools Menu

Trace

Opens the trace control dialog box. Configure and start your trace from this dialog box.

Stats

This opens the statistics configuration dialog box. From this dialog box you can setup and draw a snap-shot bar chart of your results.

Calculators

This menu option gives you access to three useful microwave calculators. These are:

- VSWR Mismatch
- Parameters
- Power Units Converter

The VSWR Mismatch calculator and the Parameter calculator have help files which describe their operation.

Help Menu

USB Power Sensor Help

Opens the application help which provides detailed descriptions of the features being used. Help on the measurement control panel is displayed when you select the help button in the dialog box.

Sensor Details

Provides information about the detected sensor being used by the application. This includes the firmware and serial number of the sensor.

About...

This provides information about the revision of the application you are using.

5 Enhanced Features

This chapter outlines the advanced capabilities of the ST CW power sensor software. There are brief outlines and descriptions of how the software can be integrated into other test environments such as C++, Agilent VEE and National Instruments® NI.

Refer to the programming reference guide for more details (S2004-90012). An electronic version is included on your Satori Technology CD.

Integrating your power sensor

The following section details how to integrate the Satori Technology software into your test environment.

A library of function calls provides a simple, but powerful interface between your application software and sensor hardware. All the function calls are contained in a dynamic link library (DLL).

To use the library, the following three files are required:

- USB Sensor Lib.dll
- USB Sensor.Lib.lib
- USB Sensor.h

These files can be found on the installation CD. The latest versions can be downloaded free of charge from the Satori website www.satori-technology.com

The file **USB Sensor Lib.dll** can reside in the same directory as your application executable file, or in a path known to your application executable file.

The file **USB Sensor Lib.lib** must reside in a path known to the linker that will link to your application.

The file **USB Sensor.h** contains definitions required by the USB Sensor function calls and must reside in a path known to the compiler that will compile your source code.

6 Troubleshooting

This chapter explains how to fix some typical software and hardware configuration issues that you may have encountered. It also provides some technical background information that can help you better understand your test environment.

How to fix “No Sensor Connected” problems

When you start your Satori Technology software application you can get the following condition message displayed - “No Sensor Connected”, refer to Figure 42 on page 51.

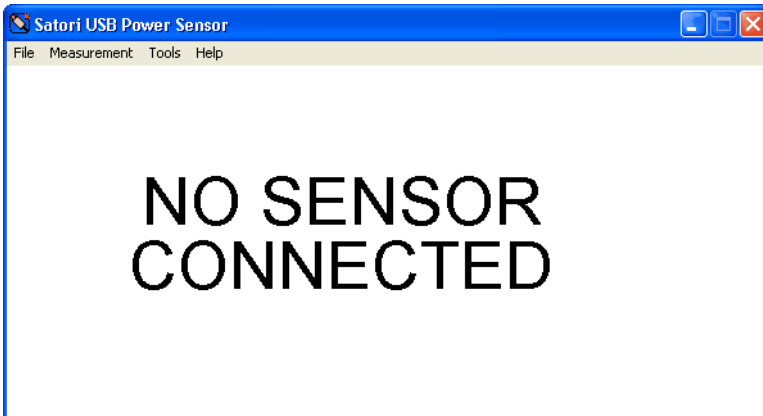

Figure 42 No sensor connected warning

This can be the result of one of the following issues:

- No sensor is attached to your PC (refer to page 52)
- The wrong USB driver has been installed (refer to page 52)
- The USB cable or USB port are faulty (refer to page 53)
- Incorrectly configured USB hub (refer to page 53)
- More than one application has been started (refer to page 54)

The following procedures will help you correct these problems:

No sensor is attached to your PC

Check all cable connections from your PC to your sensor. A connector may have been loosened and may not be making adequate contact.

This is especially important when using multiple sensor configurations.

The wrong USB driver has been installed

If the wrong USB driver has been installed then there will be no consistent communication between your sensor and PC. Use the following procedure to identify the installed driver. This procedure applies to Windows® XP operating system.

Do this	Comment
1 On your PC, select Start > Control Panel .	
2 Double-click on System .	This opens the System Properties dialog box.
3 Select the Hardware tab.	
4 Select the Device Manager button.	This opens the Device Manager dialog box.
5 Expand the list of Universal Serial Bus controllers	Click the 'plus' symbol to expand the list.
6 If the correct driver has been installed you should see the following item listed - FTDI FT8U2XX Device	Refer to Figure 43 on page 52.

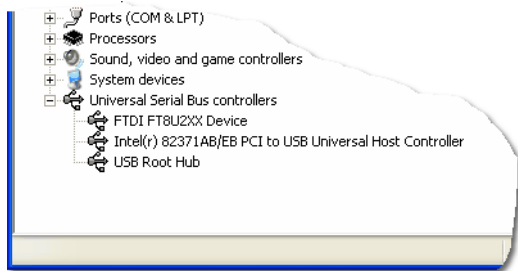

Figure 43 Correct USB driver configuration

If this is **NOT** the driver listed in your Device Manager, then use the following procedure to remove the installed driver and configure the correct driver:

Do this	Comment
1 Disconnect any sensors connected to your PC.	
2 On your PC, select Start > Control Panel .	
3 Double-click on Add or Remove Programs .	
4 Locate and select the FTDI COM driver listed.	
5 Select the Change/Remove button.	This removes the USB driver.
6 When the driver has been removed, close the Add or Remove Programs dialog box.	
7 Close the Control Panel.	
8 To install the correct USB, refer to "USB Installation" on page 13.	

The USB cable or USB port are faulty

In the event of a faulty cable or port, try the following solutions:

- Replace the cable with another high standard USB cable.
- Use another USB port on your PC. If you only have one port on your PC, connect another USB device to the suspected port (for example a mouse or printer) and verify device recognition.

Incorrectly configured USB hub

Some USB hub devices require custom driver installation. If the driver installation procedures are not followed correctly some, or all the ports provided by the hub, may not be seen by your PC.

Carefully read your USB hub manufacturer's instructions on driver installation and configuration.

If you are not sure the fault is with the USB hub, try connecting a sensor directly to your PC and verify connection using the application.

More than one application has been started

It is possible to start multiple instances of the application software. The first time the application is started it checks the available USB ports for a recognised sensor.

If the application is started again, but you only have one sensor connected, then the application will report a “No Sensor Connected” error.

Check your PC Taskbar for any minimised applications.

Unexpected measurements results

If you suspect that you are getting unexpected measurements, then use the following procedures to correct the potential fault:

- Check the status messages displayed on the right-side of the application
- Your sensor is potentially damaged
- Incorrect offset setting
- Incorrect measurement settings

Check status messages

The status messages on the right-side of the application provide information about your measurement settings and any possible limits errors. Refer to “Error and status messages” on page 42.

Your sensor is potentially damaged

If you suspect that your sensor is damaged, then connect a known signal source and verify that the sensor is measuring that source correctly. If this, or any of the other procedures do not correct the fault then contact your local representative for more information.

Incorrect offset setting

If you have made the wrong measurement offset setting in the measurement control panel, then you may see incorrect measurements.

Incorrect measurement settings

Check that you have set all the right settings in the measurement control panel. Refer to “Using the software” on page 25 for more information. If you are not sure what settings you have set, select **Measurement > Preset** to return the sensor measurement settings to the factory default settings.

How to identify your PC operating system

The procedure for installing USB drivers differs slightly depending on which version of operating system you have on your PC. Follow this procedure to identify your operating system.

Do this	Comment
1 On your PC, select Start .	
2 Highlight and right-click on My Computer .	
3 Select Properties from the pop-up menu.	This opens the System Properties dialog box.
4 Select the General tab.	Refer to Figure 44 on page 55.

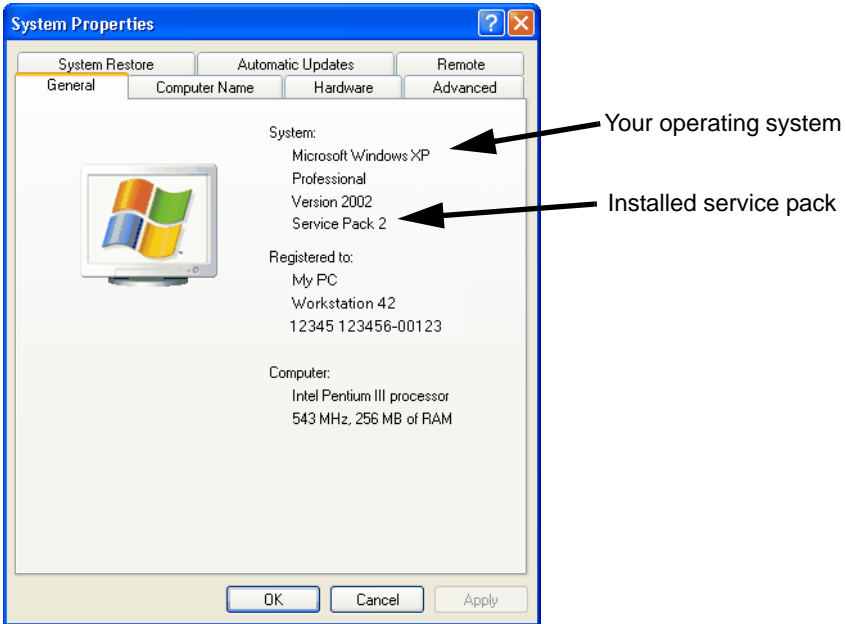

Figure 44 How to identify your operating system

Other useful information

The following sections provide some useful information about power measurement and your USB sensor.

What is zeroing?

Zeroing is a measurement process that ensures that the sensor indicates as close as possible to 0 watts when no power is applied. This ensures that the sensor gives the best possible linearity.

Due to the very low voltages that are measured by the analogue to digital converter in the sensor, some averaging is necessary and the process takes about eleven seconds. The zero should be re-measured periodically for best accuracy at low power levels. It should also be re-measured after connecting the sensor directly to equipment that is at a significantly different temperature than the sensor, when the sensor has reached operating temperature.

It is only necessary to re-zero if the power indicated when no power is applied to the sensor is worse than -55 dBm. A poor zero affects lower power measurements more than larger ones. Excessive zeroing in automatic measurement programs is not recommended as it can significantly increase program run times.

Pulse measurement and setting the duty cycle

The duty cycle facility is used to measure the 'pulse power'. This is the power measurement while an RF burst is present, when the signal is a gated burst of a sinusoidal RF signal - for example a radar pulse.

The sensor is calibrated to measure average power, and provided the pulse repetition rate is sufficiently high, a measurement of the pulse power can be obtained from the average power.

Certain assumptions are made about the RF burst, and these must be met if the measurement is to be accurate. The burst is assumed to be either on or off, in other words it does not take a finite time to ramp up or down.

The ramp up and down times should be small in relation to the on time of the signal generator. The burst is also assumed to have constant amplitude when on. The amplitude does not ring, droop or overshoot. If the pulse does not have these attributes, then the accuracy of the result is not valid.

The RF in the burst is also assumed to be un-modulated. If it were amplitude modulated, for example, then the measurements would be likely to vary with time as the modulation and the voltage measurement made in the power meter would not be synchronized.

Constant amplitude modes of modulation like phase or frequency modulation are permissible.

What is a dB?

The dBm and dB are common units occurring in power measurements. 'dB' is short for decibel. The dB is a method of describing the ratio of two powers over a very wide range and is defined as:

$$dB = 10 * \log_{10} \left(\frac{P_1}{P_2} \right)$$

The table below gives some power ratios and their equivalent dB values:

Power ratio	dB
0.001	-30.00
0.01	-20.00
0.1	-10.00
0.25	-6.02
0.5	-3.01
1	0
2	3.01
4	6.02
10	10.00
100	20.00
1000	30.00

What is a dBm?

When one of the powers is defined, again for convenience, as 1mW, then the related unit, abbreviated to 'dBm', is described as follows.

$$dBm = 10 * \log_{10} \left(\frac{P_1}{1mW} \right)$$

The table below gives some powers and their equivalent dBm values:

Power	dBm
1 μ W	-30.00
10 μ W	-20.00
100 μ W	-10.00
0.25 mW	-6.02
0.5 mW	-3.01
1 mW	0
2 mW	3.01
4 mW	6.02
10 mW	10.00
100 mW	20.00
1 W	30.00

7 Contact & Support

This chapter provides information about Satori Technology. It tells you how to get in touch and what to do if you are having problems or need more information about other products.

Contacting Satori Technology

To contact Satori Technology please contact your local representative or use the following e-mail address:

support@satori-technology.com

Our Website

The Satori Technology website provides up to date product information and news.

www.satori-technology.com

8 Safety & Specifications

This chapter provides information about the ST CW power sensor safety compliance and sensor specifications.

Safety notices

Please careful read the following information:

WARNING

A WARNING denotes a hazard. A WARNING that is not followed and adhered to could result in injury or loss of life. Do not proceed beyond the WARNING note until you have carefully read and understood the note.

Caution

A CAUTION denotes a hazard. A CAUTION that is not followed and adhered to could result in partial or complete damage of your equipment. Do not proceed beyond the CAUTION note until you have carefully read and understood the note.

Note

A NOTE draws your attention to a procedure or additional information that, if followed correctly, can prevent mis-use of the your equipment. It also points out additional information that can help you get more from your system.

WEEE Directive

Satori Technology will undertake a “take back” policy for all sensor products no longer fit for purpose and dispose of the said products under the European WEEE directive.

Please contact Satori Technology for more details, refer to “Contacting Satori Technology” on page 59.



Product descriptions and requirements

The ST CW power sensor descriptions and PC specifications are as follows:

Minimum PC requirements

Your minimum recommended PC specifications are:

PIII Windows XP SP2
256 RAM
600 MHz
USB Port (1.0 or greater)
CD Drive

ST124SMA Description

- ST124SMA USB power sensor
- Frequency range: 10MHz to 12.4GHz
- Amplitude range: -50dBm to +20dBm
- RF input connector SMA male

ST185SMA Description

- ST185SMA USB power sensor
- Frequency range: 10MHz to 18.5GHz
- Amplitude range: -50dBm to +20dBm
- RF input connector SMA male

ST265SMA Description

Contact your local Satori Technology representative for more information.

Index

A

attenuator33

C

cautions61
 compliance61
 connecting multiple sensors23
 connection torque22
 contact Satori59
 contents of your system4

D

dB57
 dBm58
 declaration of conformity62
 driver
 windows XP SP1 16
 windows XP SP2 13
 duty cycle30, 31, 32, 56

E

embedding software49
 enhanced features49
 error messages42
 extra features49

F

file menu47
 forced zero44

G

GPRS measurement32
 GSM phone measurement32
 GSM signal measurement31

H

hardware configuration21
 help menu48
 high limit43
 high limit exceeded43

I

icons46
 identify operating system55
 install USB drivers13
 installed USB driver16
 installing software9
 introduction3

K

key features3

L

license agreement10
 low limit exceeded44

M

make a measurement26
 manual cal factors45
 measure GSM signal31
 measure power greater than +20dBm ...33
 measure pulse power30
 measure using more than one sensor ...28
 measurement menu47
 measurement offset33
 measurement procedure26
 menu
 file 47
 help 48
 measurement 47
 tools 47
 menu options47
 multiple sensor connection23
 multiple sensors28

N		T	
no sensor connected	51	tools menu	47
notes	61	torque for connection	22
		troubleshooting	51
O		U	
offset measurement	33	unit under test (UUT)	22
operating system identification	55	USB connection	21
overloaded sensor	43	USB driver installation	13
		USB driver problems	52
		using the software	25
		UUT connection	22
P		W	
PC specifications	63	warnings	61
procedure for installing software	9	website	59
programming guide	49	WEEE directive	63
pulse measurement	30, 56	welcome	3
		What is dB	57
		What is dBm	58
		Windows XP installation	13
		wrong USB driver	52
R		Z	
return products	63	zero sensor	26
		zeroing	
		what is it 56	
S			
safety notices	61		
sensor driver installation	13		
sensor overload	43		
sensor to your UUT connection	22		
sensor zero	26		
serial number	29		
software			
how to use 25			
software installation	9		
software license agreement	10		
software menus	46		
ST124SMA Specifications	63		
ST185SMA specifications	63		
ST265SMA specifications	63		
start-up screen	25		
status messages	42		
system integration	49		